

# Circuit Diagram

Paper Deck  
Side Paper Deck-X1

**Canon**



## IMPORTANT

This documentation is published by Canon Inc., Japan, to serve as a source of reference for work in the field.

Specifications and other information contained herein may vary slightly from actual machine values or those found in advertising and other printed matter.

Any questions regarding the information contained herein should be directed to the Copier Service Department of the Sales Company.

This documentation is intended for all sales areas, and may contain information not applicable to certain areas.

Reproduction without permission not allowed.

Use of this manual should be strictly supervised to avoid disclosure of confidential information.

***COPYRIGHT 2001 CANON INC.***

*Printed in Japan*

### Caution

Use of this manual should be strictly supervised to avoid disclosure of confidential information.



## Contents

1 Deck Driver PCB .....	1
Deck Driver PCB (1/8) [A501] .....	1
Deck Driver PCB (2/8) [A502] .....	2
Deck Driver PCB (3/8) [A503] .....	3
Deck Driver PCB (4/8) [A504] .....	4
Deck Driver PCB (5/8) [A505] .....	5
Deck Driver PCB (6/8) [A506] .....	6
Deck Driver PCB (7/8) [A507] .....	7
Deck Driver PCB (8/8) [A508] .....	8



1 Deck Driver PCB  
Deck Driver PCB (1/8) [A501]

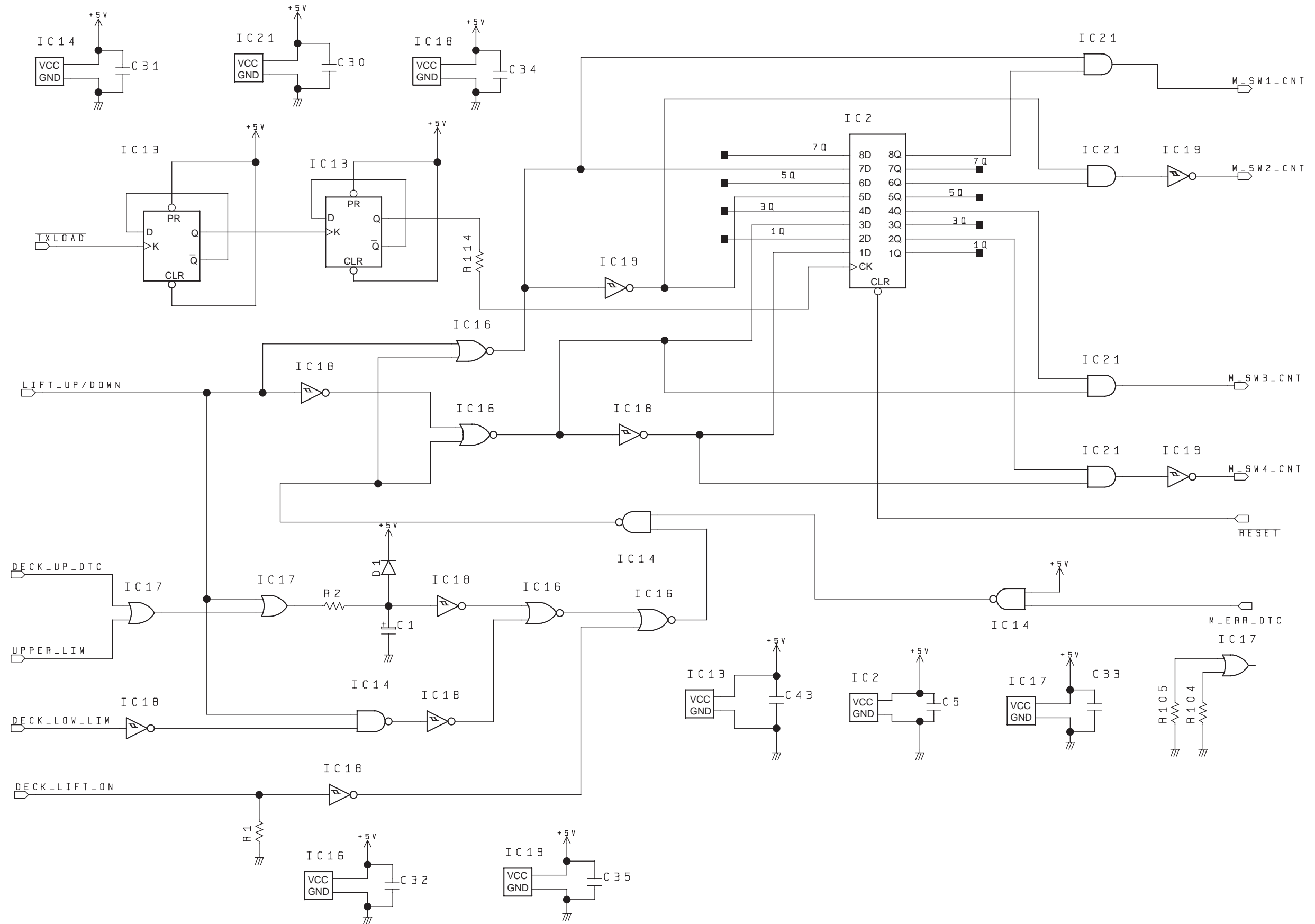

F-1-1

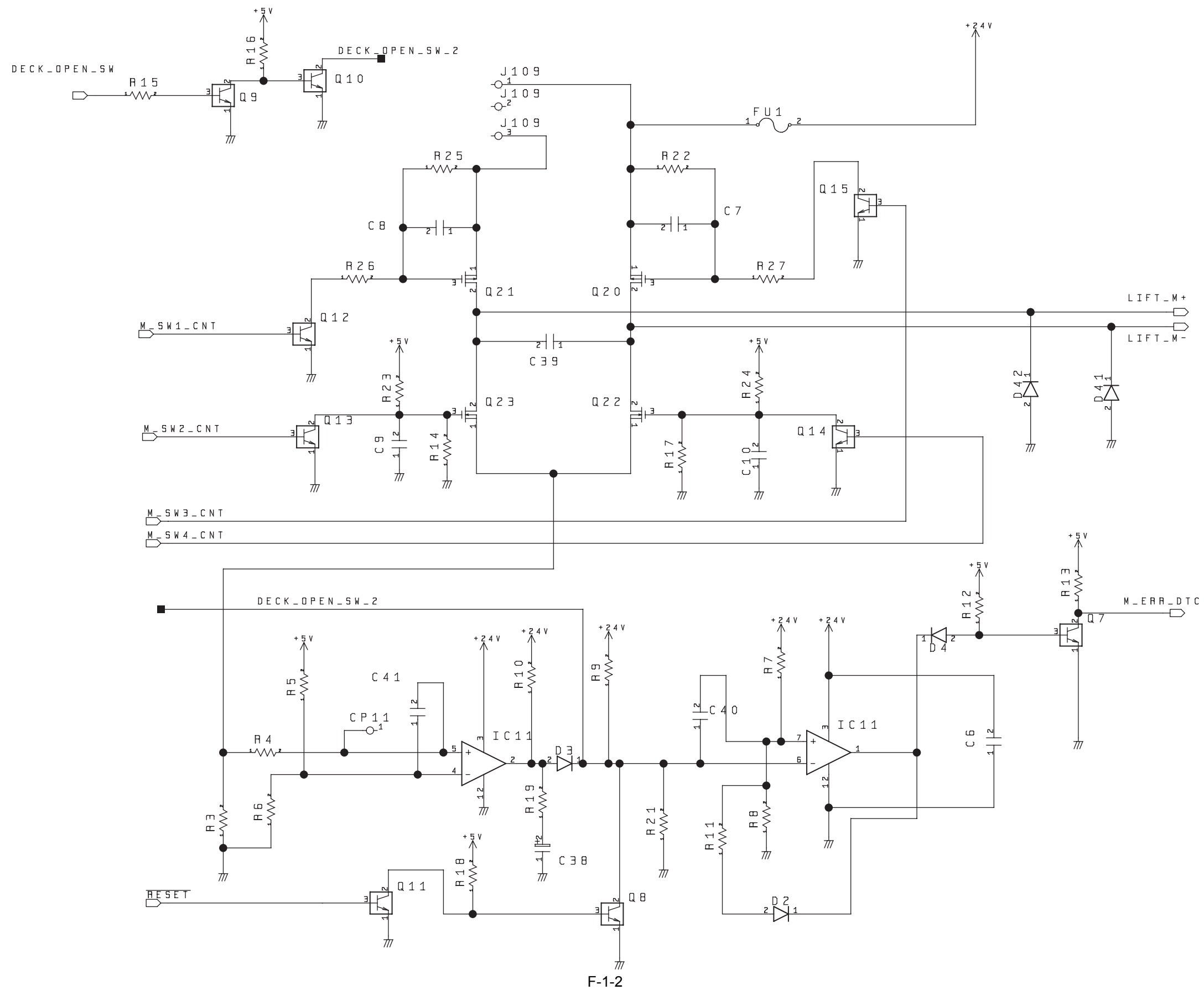



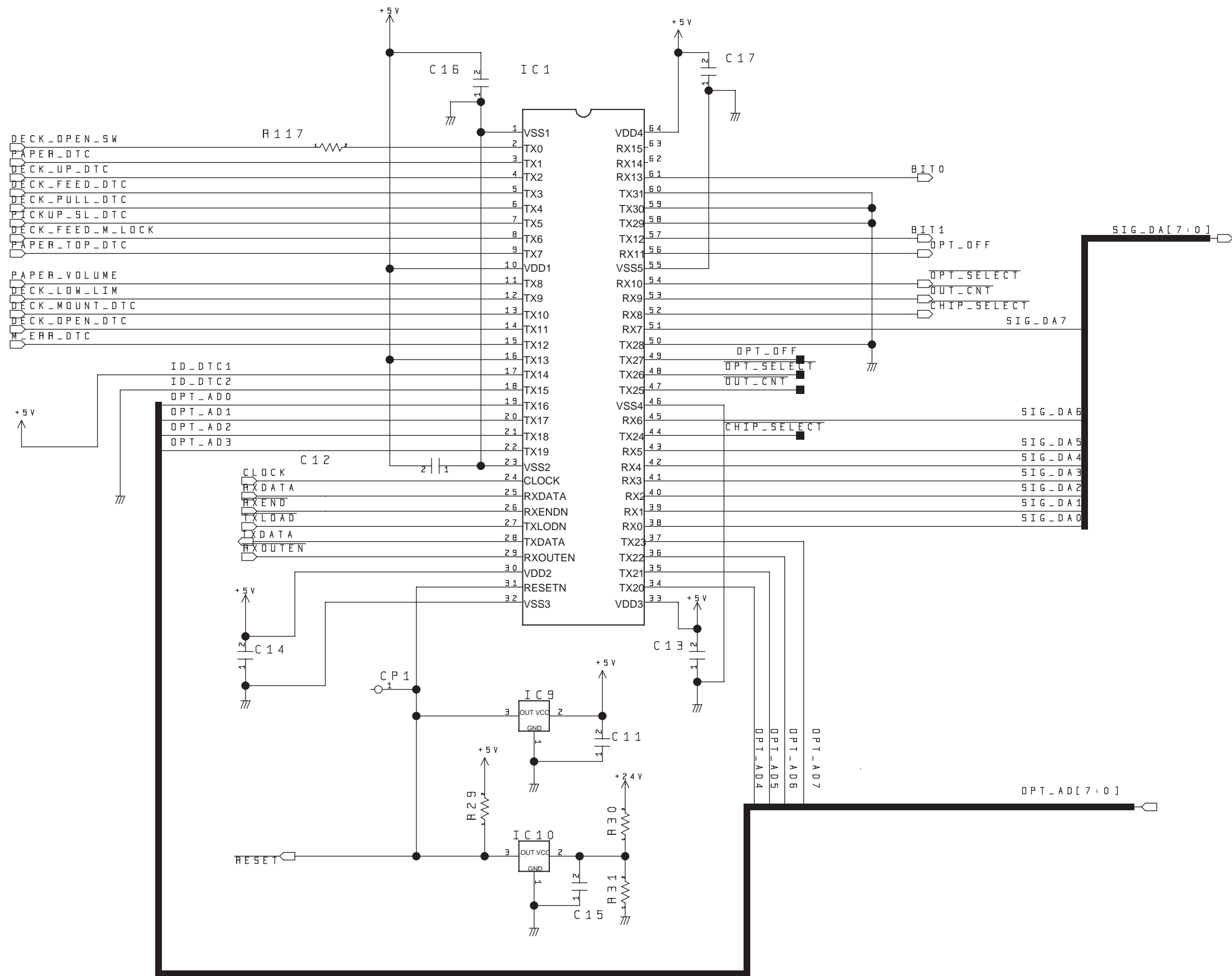

F-1-3

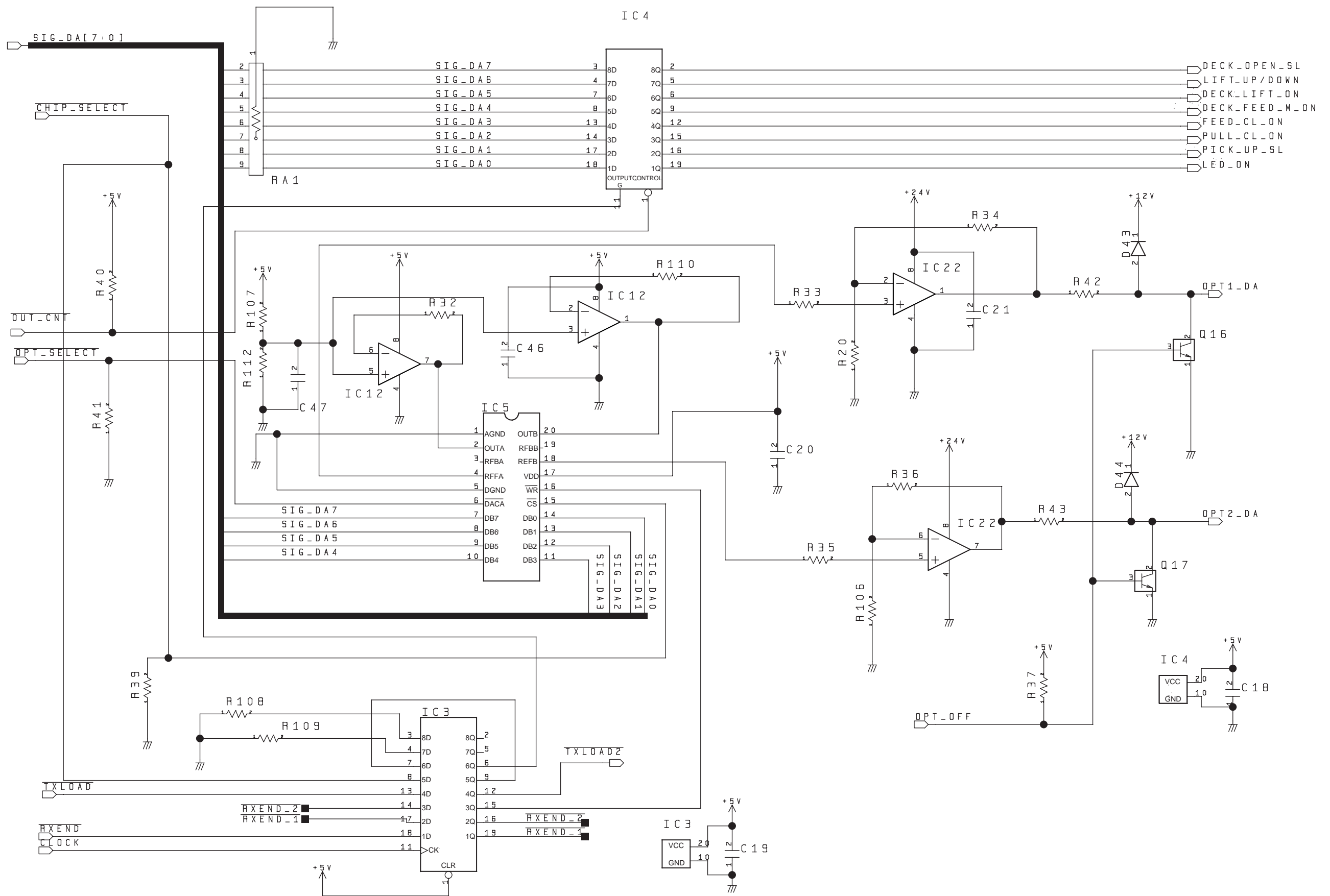

F-1-4

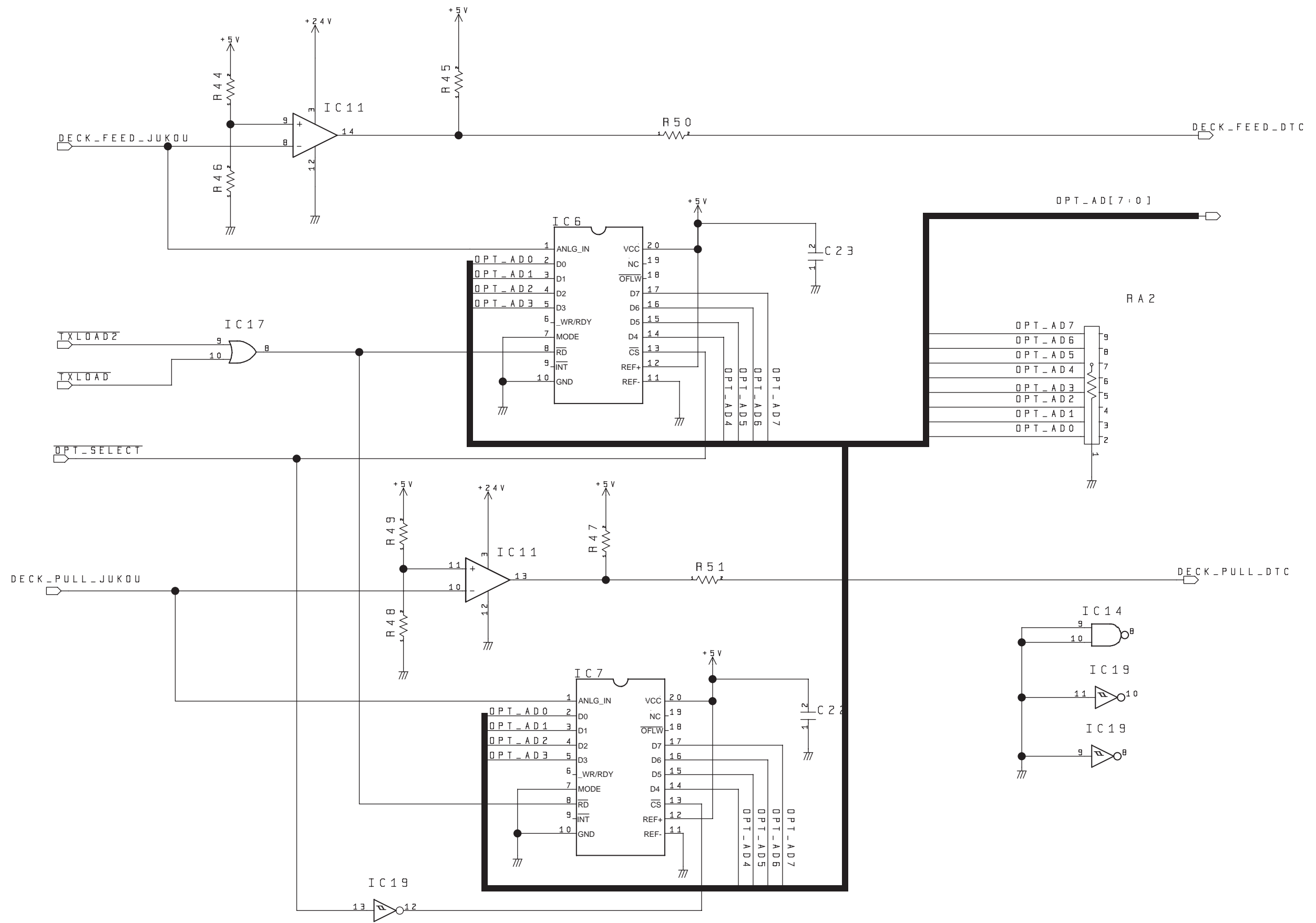

F-1-5

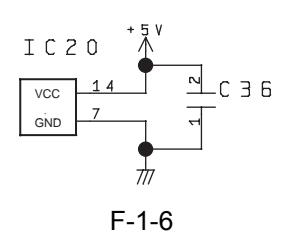
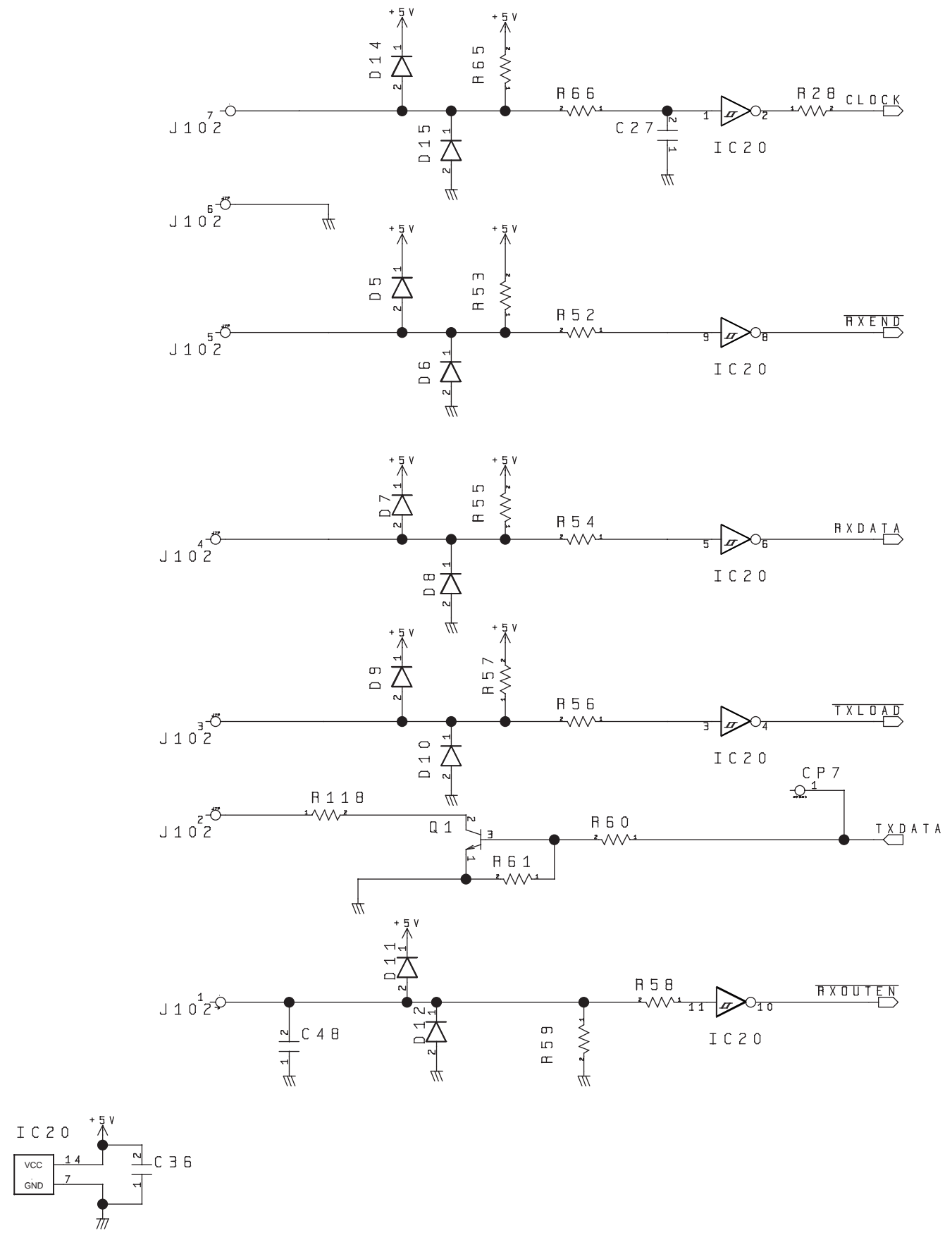
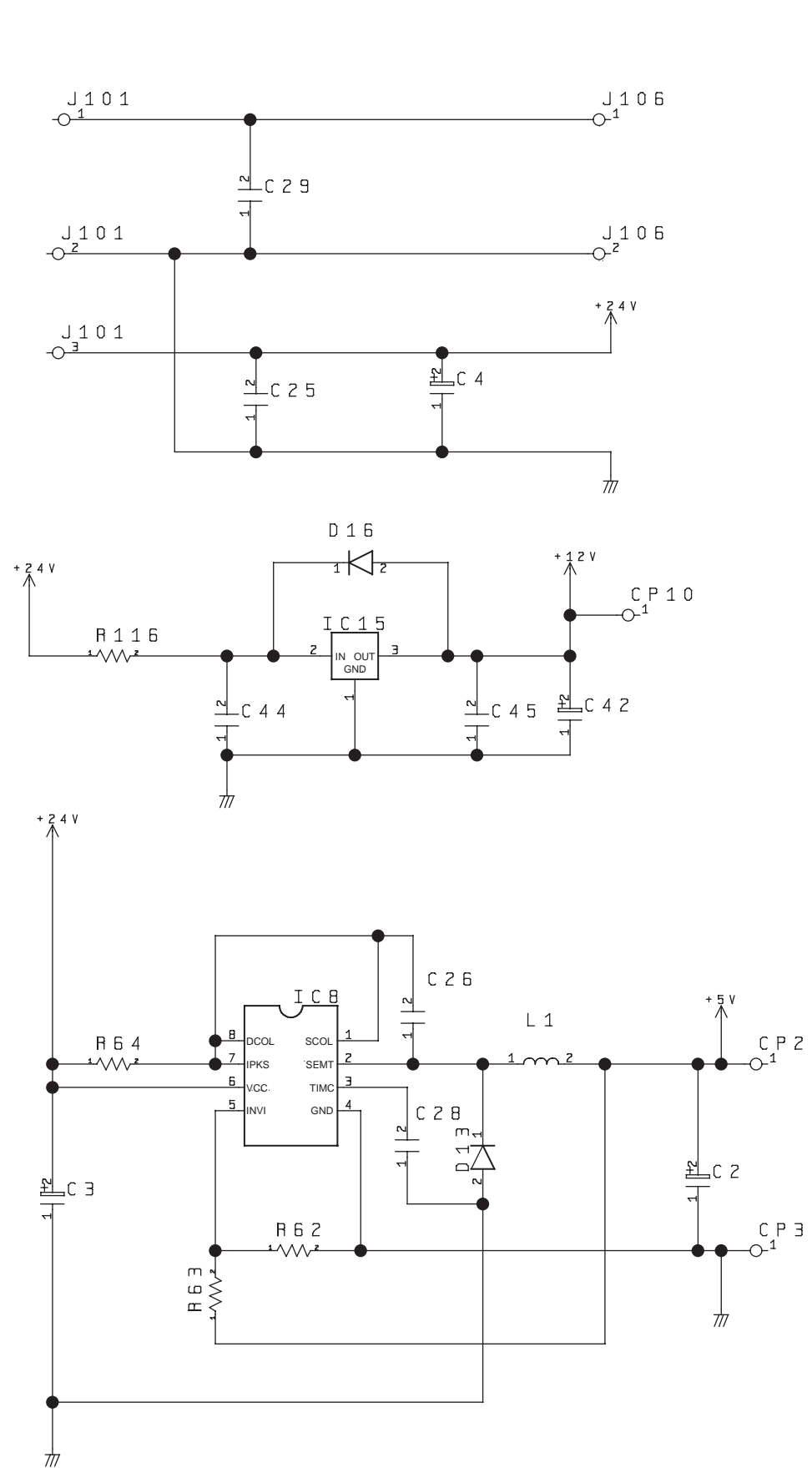

Deck Driver PCB (7/8) [A507]

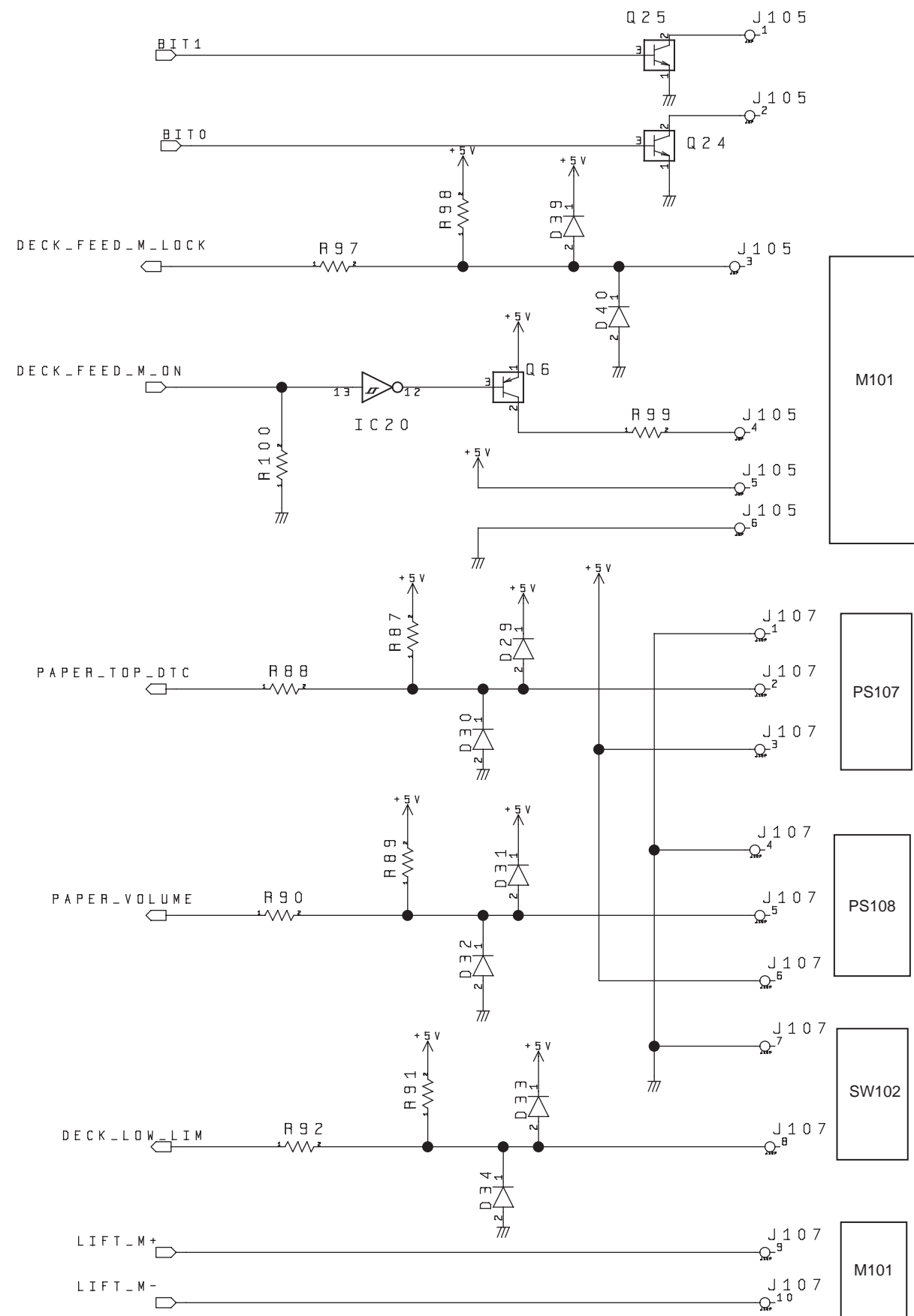

M101

PS107

PS108

SW102

M101

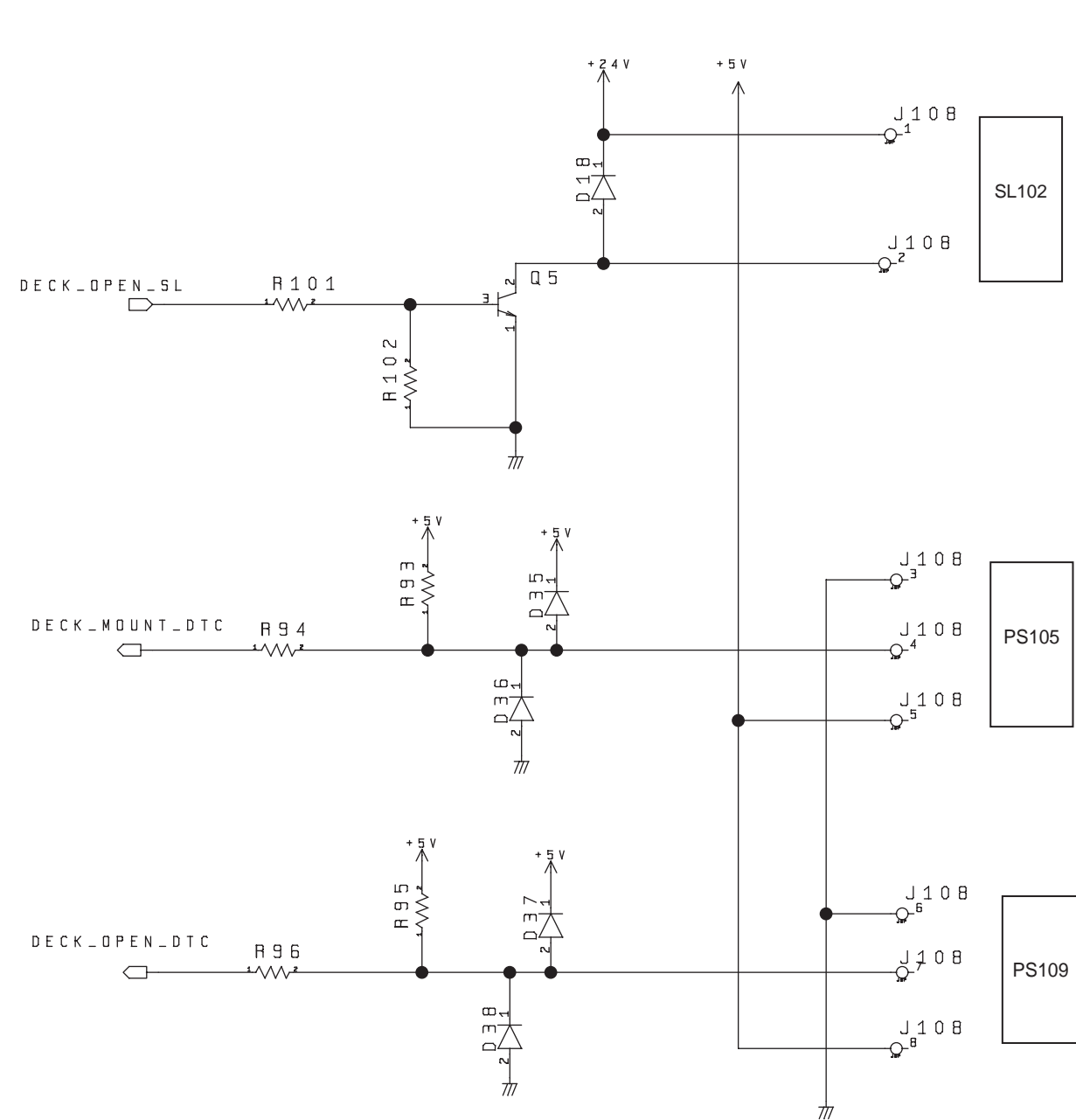

SL102

PS105

PS109

F-1-7

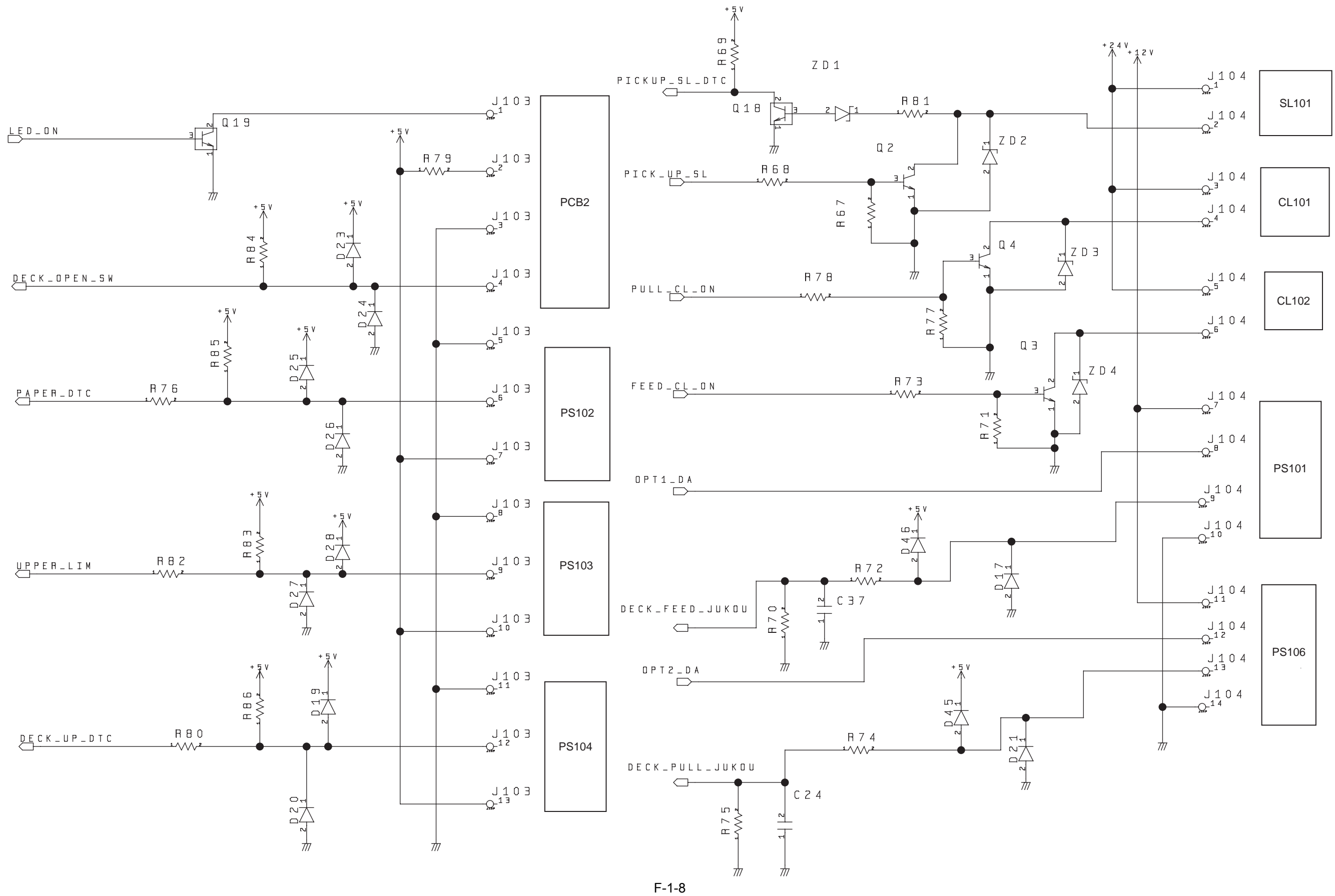

F-1-8







Feb 7 2006

**Canon**